

SET "HAWAY"

yarns *IBIZA* and *RAFIA*



YARN
ADRIAFIL YARNS

TOP

MATERIAL REQUIRED

100g **Rafia**, Orange no. 69. Knitting needles no. 5. Crochet hook no. 4.00. Tapestry needle.

SIZE: IT 42 (40-44) - US 8 (6-10) - UK M (S-L)

PATTERN STITCHES

Knitted stitch
Garter stitch
Garter stitch with buttonholes (work over a multiple of 9):

Rows 1 and 2: knitted stitch.

Row 3: * 1 st. with buttonhole (= knit up the first stitch on the left knitting needle and, without dropping the stitch from the needle, pass the yarn to the front, wind it around the thumb of your left hand, to make a buttonhole, then pass the yarn behind and knit the same stitch again in the back loop; 1 yo, slip the 2 stitches worked on the yo.), k8*, rep. from * to *.

Row 4: knitted stitch.

Row 5: rep. from row 1.

Chain stitch

GAUGE

10 cm x 10 using knitting needles no. 5 in knitted st. = 16 sts. and 20 rows.

WORKING INSTRUCTIONS

Work the tank top starting from the top.

Edge: using knitting needles no. 5 cast on 9 sts. and work in garter st. with button hole for 36 cm., then in garter st. for another 36 cm. Bind off the stitches.

Back: to work the left section, pick up 19 sts. along the left edge of the border, on the last 34 rows; work in knitted st. decr. on right of work, inside 1 st., 1 st. every 8 rows. twice (k2 tog.). When work measures 13 cm. from the edge, incr. rightwise, inside 1 st., 1 st. every 4 rows 7 times (knit 2 sts. in 1 stitch). When work measures 26 cm. from the edge, stand off work. To work the right section, on the left of the border, skip the edge st. of the 20 rows after the picked up stitches of the part you have just worked; pick up 19 sts. along the edge of the next 34 rows; work to match the left section; to work in the decr. on the sides, slip 1, k1, pass slipped st. over. Place both the sections on the same knitting needle, working first the stitches of the left section and then those of the right. Cont. incr. at each end, inside the first and the last 14 sts., 1 st., 1 st. after 4 rows, after another 4 rows incr. 6 sts. evenly. When the two sections 8 cm., bind off all the stitches.

Front: pick up 62 sts. along free part of the edge and work in knitted st. On each side, decr., inside 1 st., 1 st. every 8 rows 3 times (rightwise k2 tog.; on left of work, slip 1, k1, pass slipped st. over). When work measures 13 cm. from the edge, incr. at each end, inside 1 st., 1 st. every 6 rows twice (knit 2 sts in 1 stitch). When work measures 34 cm. from the edge, bind off all the stitches.

FINISHING

Sew up the right side. With the crochet hook, cast on a 150 cm. chain, and, starting from the bottom of the left side, pass it into the 2 edge sts., pushing it in and crossing it every 2 rows to the ends of the edge; tighten and knot. For the back opening, using the needle with the yarn tripled work strings of increasing widths between one edge and another so as to join them: to bind the strings, pull out the needle from the edge st., pass over the same edge and, from the wrong side, come out through the right side; throw the yarn horizontally, go to the other edge and repeat the same steps to complete the neckline.

PAREO

MATERIAL REQUIRED

300 g printed **Ibiza** no. 30 wound double; several g. **Rafia**, Orange no. 69 wound double. Knitting needles no. 9. Crochet hook no. 6. Tapestry needle.

SIZE: IT 40 (42-44) - US 6 (8-10) - UK S (M-L)

PATTERN STITCHES

Garter stitch
Double crochet

GAUGE

10 cm x 10 using knitting needles no. 9 and the yarn Ibiza wound double in garter st. = 9 sts and 15 rows.

WORKING INSTRUCTIONS

Work in a single piece. Using knitting needles no. 9 and the yarn Ibiza wound double, cast on 78 (83-88) sts. and work in garter st. To shape the pareo, decr. on each side, of the 2 centre sts. and on the outer edges 1 st. every 12 rows 3 times (= a total of 12 decrs.). When work measures 31 (34-37) cm., bind off the rem. stitches.

FINISHING

To make the belt, with the crochet hook and the yarn Rafia wound double, cast on a 75 cm chain, then work in dc. along the upper edge of the; cont. by working a 75 cm. chain; Break off and bind the yarn. Knot the ends of the belt.

Pareo design

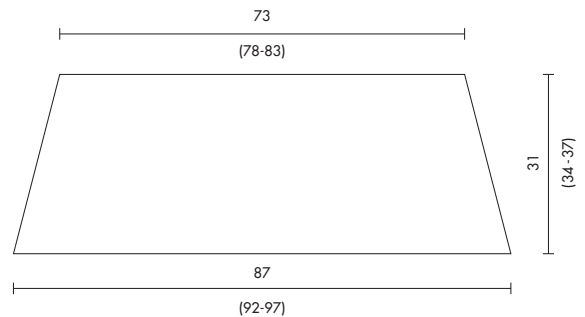

BAG

MATERIAL REQUIRED

A total of 100 g of yarns including: 50 g printed **Ibiza** no. 30, 50 g **Rafia**, Orange no. 69. Knitting needles no. 11. Crochet hook no. 8. 1 brown bacalite handle with 23 cm opening. Tapestry needle.

DIMENSIONS: 30x32 cm.

PATTERN STITCHES

Fancy stitch (work over even sts.):

Row 1: k1, * 1 yo., k2, slip the yo on the 2 knitted sts *, rep. from * to *, k1

Row 2 and all even rows: purled stitch.

Row 3: rep. from row 1.

Double crochet

Reverse stitch: work like dc. from left to right.

GAUGE

10 cm x 10 using knitting needles no. 11 and the two joined yarns work in fancy st. = 10 sts. and 10 rows.

WORKING INSTRUCTIONS

The bag consists of two equal sections. To make the first section, with using knitting needles no. 11 and the two yarns joined together, cast on 30 sts. and work in fancy st. When work measures 26 cm., per to shape the upper edge, bind off the 14 centre sts. and complete the two sections separately; bind off again centrewise, every 2 rows, 1 st. 3 times. At the same time, when work measures 28 cm., decr. on each side, 1 st. every 2 rows. twice. Bind off the rem. st.. Work the second section of the bag in the same way.

FINISHING

Sew up the side edges and the bottom. With the crochet hook and the two yarns joined together, trim the side edges and the upper edge with a row in dc. and on reverse stitch. Sew on the handles.

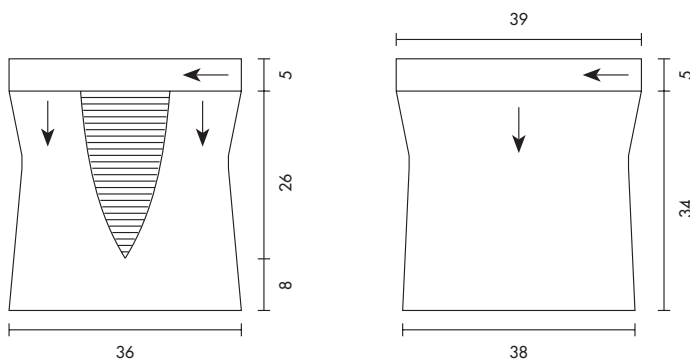
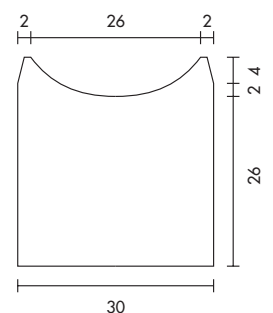

Top design

Bag design