

# PAG. 18 MINIPULLOVER



## YARNS ADRIAFIL YARNS

### MATERIALS

A total of 200 g. yarn 100% fine "Lana Lavatrice" of which: 100 g. red no. 17, 50 g. colour cream no. 11 and 50 g. colour blue no. 77.  
Knitting needles no. 3 1/2 and no. 4. 3 buttons.  
Tapestry needle with rounded tip.

AGE: 9-12 months

### PATTERN STITCHES

Elastic rib

Rib stitch 1/1

Two-colour rectangular stitch: work over 4 sts. + 1.

Rows 1 and 7: (red) in knitted stitch

Rows 2 and 8: (red) in purled stitch.

Rows 3 and 5: (cream) k/1., \* k/3, 1 slipped st. (= slip the next st. working as for purl) \*. Repeat from \* to \* and end with k/1.

Rows 4 and 6: (cream) k/1., \* 1 slipped st., k/3 \*. Repeat from \* to \* and end with k/1.

Rows 9 and 11: (green) k 2, \* 1 slipped st., k/3 \*. Repeat from \* to \* and end with 1 slipped st., k/3

Rows 10 and 12: (green) \* k/3, 1 slipped st. \*. Repeat from \* to \* and end with k 2

Row 13: knit up from Row 1

### SAMPLE

Work a 10 x 10 cm square with knitting needles no. 4 in two-colour rectangular stitch = 26 sts. and 46 rows

### WORKING INSTRUCTIONS

**Back:** Cast on 71 st. with knitting needles no. 3 1/2 and the red and work 4 rows in elastic rib. and 4 rows in rib st. 1/1, equal to 1,5 cm. Cont. with knitting needles no. 4 in two-colour rect. st. increasing 4 sts. in row 1 When the work measures 13 cm. from the edge, equal to 60 rows, to shape the armholes bind off at each side 7 sts. Cont. per 10,5 cm., equal to 48 rows, then, bind off rem. 61 sts.

**Front:** Work to match Back until the work measures 19,5 cm. from the

edge, equal to 90 rows. To shape the neckline, bind off 15 centre stitches and cont. the two parts separately bind off again, towards the centre, every 2 rows, 2 sts., 1 st. twice. When the work measures 4 cm. from beg. of the neckline, equal to 18 rows, bind off rem. 19 sts for each shoulder.

**Sleeves:** Cast on 35 sts. with knitting needles no. 3 1/2 and the red and work 4 rows in elastic rib. and 4 rows in rib st. 1/1, equal to 1,5 cm. Cont. with knitting needles no. 4 in two-colour rect. st. increasing 6 sts. in the 1st row. At the two sides increase 1 st. every 6 rows 11 times When the work measures 16 cm. from the edge, equal to 74 rows, Bind off together all the stitches

### MAKING UP AND FINISH

Sew the right shoulder. With knitting needles no. 3 1/2 and the red yarn knit up 72 sts. around the neckline and work 4 rows in elastic rib. and 4 rows in rib st. 1/1. Graft stitches with the tapestry needle. In the same way knit up 38 sts. along the left shoulder and work an edge like the prev. working in row 3 in rib st. 1/1, 3 eyelets of 2 sts. spaced evenly. Fit and join the Sleeves. Join the end of the edge of the left shoulder. Sew the sides. Sew on the buttons.

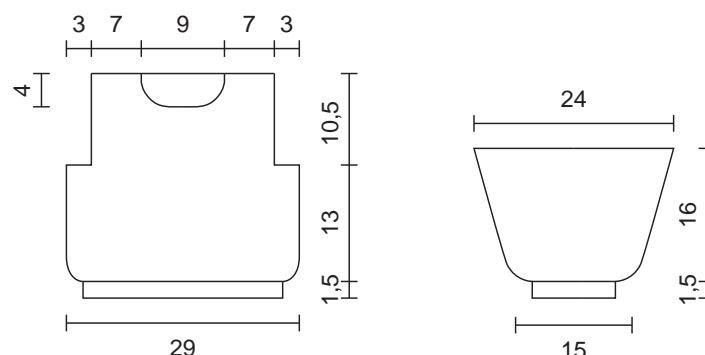

# PAG. 18 CHILDREN'S SOCKS



## YARNS ADRIAFIL YARNS

### MATERIALS

Total of 200 g. 100% fine "Lana Lavatrice" yarn of which 150 g. colour blue no. 77 and 50 g. red no. 17.  
Knitting needles no. 4. 50 elastic band, height 3,5 cm.  
Tapestry needle with rounded tip.

AGE: 9-12 months

### PATTERN STITCHES

Knitted stitch

Garter stitch

### SAMPLE

Work a 10 x 10 cm square with knitting needles no. 4 in knitted stitch. = 25 sts. and 32 rows

### WORKING INSTRUCTIONS

**Back:** Work beg. with a leg. Cast on 35 sts. with knitting needles no. 4 and the red and work 12 rows in garter st., equal to 3 cm. Cont. in Knitted stitch with the blue yarn and increase 6 sts. in Row 1. When the work measures 14 cm. from the edge, equal to 46 rows stand the work. Work the other leg in the same way, then, place the two parts on a single knitting needle and cast on 8 sts. at the centre for the crutch. When the work measures 36 cm. from the edge, equal to 116 rows, bind off together all the stitches

Front: Work to match back.

**Laces:** Cast on 5 sts. with knitting needles no. 4 and the blue yarn and work in knitted stitch. per 50 cm. Bind off sts. Work 2 laces.

### MAKING UP AND FINISH

Sew the inner part of the legs and crutch. Sew the sides. Fold the waist edge inwards by 4 cm and sew with invisible stitches leaving a small ope-

ning on one side. Fit the elastic band and sew up the ends. Close the waist edge. Fold the laces in half, lengthwise and sew up the edges. Using a safety pin, fit a lace zig-zag on each side, for the first 10 cm. of the leg, but not on the edge.

